

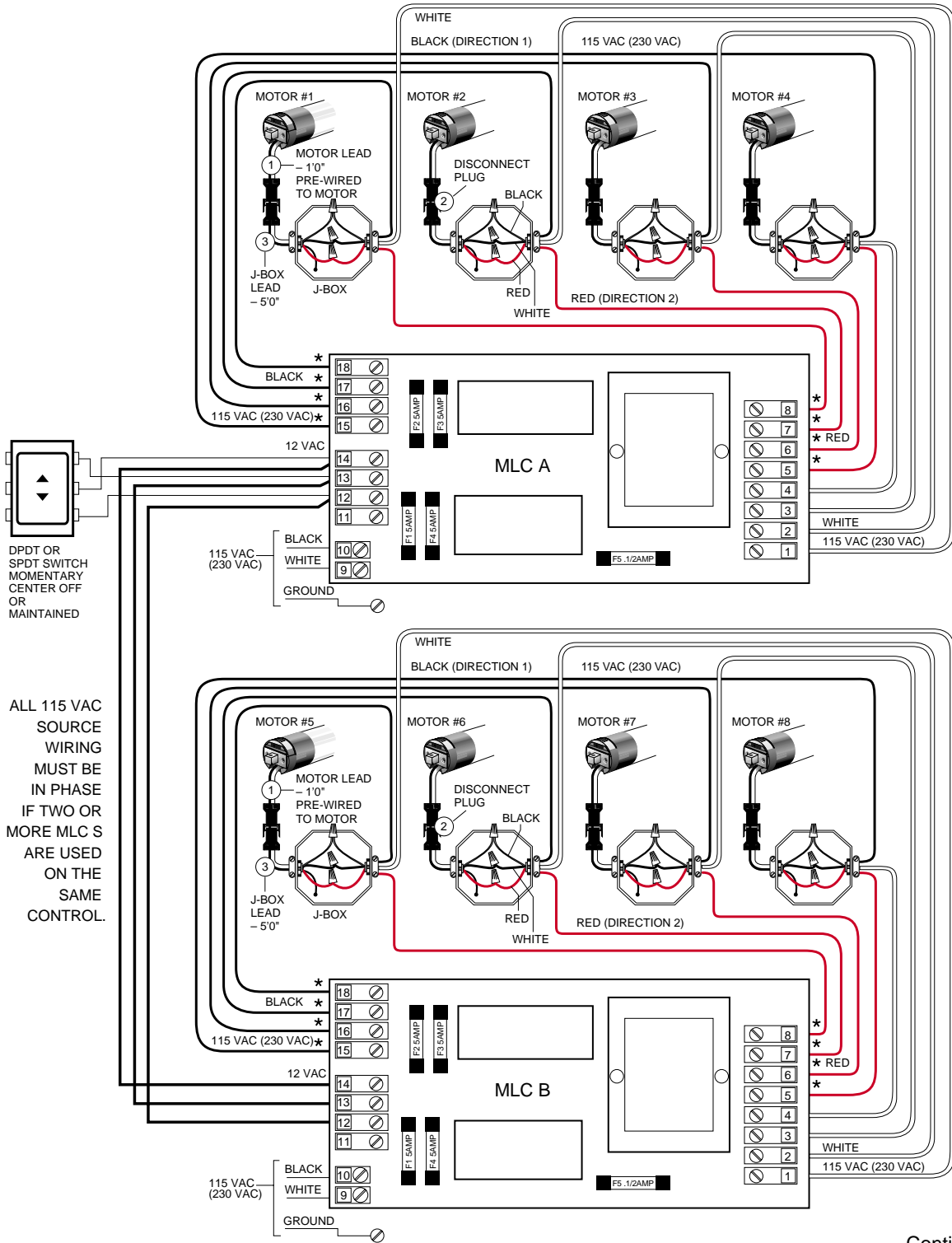

MLC™ – ElectroShade® Wiring Diagram For Std. Motors

MLC – Wiring Diagram

How to connect two or more four (4) motor MLC™ Motor Logic Controllers having five or more standard type motors on one switch.



Continued 

MechoShade Systems, Inc.
 42-03 35th Street, Long Island City, NY 11101
 Telephone: 718-729-2020
 Fax: 718-729-2941 / 800-899-8081

E-mail: info@mechoshade.com
 Internet Web Site: <http://www.mechoshade.com>

4.18
 MS2200 - 1/1/04



ElectroShade® Electrical Notes For Standard Motors

Line Voltage Switching (1-2 motors)

Low Voltage Control with IQ/MLC™, MLC™ or FTS's (3 or more motors)

All electrical control equipment (Switches, MLCs™, IQ/MLCs™, SACs, WACs, photocells, anemometers FTS units, etc.) as indicated is furnished only by MechoShade Systems, Inc., installed and connected by (Electrical Contractor) or (turnkey by the window covering contractor).

All electrical control equipment must be wired in accordance with wiring diagrams and Standard Electrical Notes prepared by MechoShade Systems, Inc. and in accordance with the N.E.C. and local codes.

Parallel and/or series wiring of two or more motors on a single switch or any other similar combination will void any applicable warranty and cause improper operating, premature motor failure and burnout if not otherwise instructed

All wiring diagrams have been prepared for right-hand motors regular-roll, or left-hand motors reverse roll which are wired similarly. Right-hand motors, reverse-roll and left-hand motors regular-roll, require reversing the red and black motor wires at the MLC or IQ/MLC or at the switch. This will prevent the motors from running in opposite directions when left-hand regular-roll or right-hand reverse-roll motors are installed.

All control equipment, MLC's (Motor-Logic Controllers) and all equipment that may have a transformer for A/C low voltage must be wired in phase. If not in phase, premature transformer and/or motor burnout and inconsistent control operation may occur. IQ/MLC's have 12 VDC output and may be wired out of phase.

Electrical-control equipment may contain electro-mechanical relays, adjustment points, fuses, indicator lights, etc. These must be accessible for future service and adjustment in a readily available location during normal working hours without disruption to the existing operations. This equipment shall be coded by the Electrical Contractor to indicate shade location and specific motor controlled at control equipment and circuit breaker. As-Built Drawings shall be provided by others for future service.

IQ/MLC's have dip switch controller(s) and must be installed in a readily available location for proper service and future changes.

All motors are furnished with disconnect plugs for below ceiling installation. Hard wiring will void all responsibility for cost of servicing and may void warranty. The MechoShade Warranty does not include the cost of labor to remove or install or access to MechoShade equipment as specifically stated in the MSS warranty.

Green motor wires are to be fastened to the ground junction boxes, conduits, or another suitable building ground.

The standard ElectroShade® motor lead is a PVC 4 conductor #18 standard cable approximately one-foot (305mm) long with a 4-conductor disconnect pole type plug.

The standard ElectroShades are furnished with a 115 VAC (230 VAC) motor lead, approximately one foot (305mm) long, with a locking disconnect plug. A standard junction box lead, approximately 5 feet (1525mm) long, is furnished with a disconnect plug which is compatible with the plug on the motor lead.

Line Voltage Switching of one to two motors

One or two motors can be wired on a single double-pole, double-throw switch. Please refer to pages 4.09 and 4.10 for point-to-point connections.

Low Voltage Switching of three or more motors

Three or more motors wired to a single switch require the use of a four (4) motor controller such as the MLC or IQ/MLC. Five to eight motors require two such controllers; nine to twelve motors require three; and so forth. For MLC point-to-point connections see pages 4.16 and 4.17, and for IQ/MLC see pages 4.26 and 4.27.

Some point-to-point wiring diagrams may not include motor disconnect-plugs, junction boxes, and cable raceways that may be essential for a complete installation.

Note: Maximum distance low voltage wire run connected in series is 400 ft.

Conditioned Line Requirements

Line voltage must be maintained between 108 and 132 Volts for 115 VAC systems and 207-253 Volts for 230 VAC systems. In the event of spikes or drops in line voltage in excess of 10% the system may lose Memory/Programming.

Operating voltage below 108 Volts (207 Volts) (Brown-outs) may cause unanticipated performance of the motors and control system. Discontinuance of power (shut-off) will not effect IQ/MLC memory of Intermediate Positions.

FTS Double Motor system —115VAC (230VAC) utilizes a control module with low voltage switching. Ten (10) or more control modules may be wired in series or in parallel for a single master switch which shall be double pole double throw.

Continued 

MechoShade Systems, Inc.
42-03 35th Street, Long Island City, NY 11101
Telephone: 718-729-2020
Fax: 718-729-2941 / 800-899-8081

E-mail: info@mechoshade.com
Internet Web Site: <http://www.mechoshade.com>

4.48
MS2200 - 4/1/04



ElectroShade® Electrical Notes For Standard Motors

Standard Motor Switching

The following is a brief summary of the various switching configurations that can and must be used with ElectroShade® standard motors.

Line Voltage Switching

1. One Motor, One Switch: This arrangement requires a double throw (on/off/on) switch. Either single or double-pole switches can be used. (MechoShade® Systems stocks only double-pole, double-throw switches as standard equipment.)

2. One Motor, Two or More Switches: A multi-switch command enables two or more momentary switches to be used with a single motor.

3. Two Motors, One Switch: A double-pole, double-throw switch (D.P.D.T.) is required and can be momentary or maintained.

4. Two Motors, Two or More Switches: Momentary center off switches must be used.

5. Remote Control: Wireless transmitters and receivers are available.

IQ/MLC™ Four Motor Controller

1. Four Motors, Four Local Switches and Two Master Switch Ports With 3 Auto Intermediate Stop Positions: Each IQ/MLC handles up to four motors. Three button switches provide intermediate window positioning at the touch of a button. Motors can be assigned to any combination of the four motors and four Local Switches connected to an IQ/MLC to create groups and sub groups. Master Switch controls all.

For 1 to 4 motors require one IQ/MLC. Five to eight motors require two IQ/MLC's. Nine to twelve motors require three, and so forth.

2. Intermediate Stop Positions: Three intermediate stop positions plus full up and full down. Five positions total. Custom set intermediate stop positions or auto stop at 25%, 50% and 75% of window height.

3. Two modes of operation: "Uniform Mode" for uniform window covering operation and building exterior. Shades may only stop at preset positions. "Normal Mode" for five auto stop positions plus stop anywhere on the window.

4. Internal Motor/Switch Assignments: Motors and switches can be assigned to each other by adjusting the internal on/off Switch/Motor Dip Switch controls.

5. Optional RS232/485 Interface: RS485 protocol with a PC requires a 485 PC card or an optional IQ/MLC RS232 or 485 Adapter. Up to 5 zones per interface adapter, up to 12 IQ/MLC units per zone. Allows a total of 60 control units per interface.

MLC™ Four Motor Controller

1. Four Motors, Master Switching Only: Each MLC handles up to four motors. Momentary or maintained switches can be used. Master.

2. Two or More Master Switches: Each switch must be a momentary switch. Any switch will control all the motors simultaneously. Master switching only.

3. Remote Control: Wireless transmitters and receivers are available. Optional.

SkyLighter™ Double Motor System (SDMS/FTS)

1. SkyLighter™ Double-Motor Tension System: SkyLighter shade operation utilizes a pair of operating motors with a low voltage Double-Motor Control Module to establish and maintain a taught horizontal or inclined shade. A single Double-Motor Control Module is required for each pair of operating motors. Two (2) or more SDMS modules can be wired in parallel or series to a single momentary contact switch.

AAC SolarTrac™ System

1. AAC SolarTrac™: A PC based user-defined program that automatically adjusts window shades to the year/day solar condition. Determines the microclimatic conditions and adjusts the shades incrementally on the window to anyone of 5 or more positions on a window. All shades are adjusted in accordance with the solar load, solar penetration and the particular facade of solar orientation as established by the user.

Low Voltage Accessories / Definitions

1. Sun-Activated Control (SAC): The SAC module is furnished with a "K" Value photo sensor. The SAC module has manual/auto mode selector plus master switching in the manual mode. An optional Remote Manual/Auto Switching Controller is available. Compatible with the MLC and IQ/MLC motor controllers. The IQ/MLC requires an optional interface.

Continued 

MechoShade Systems, Inc.
42-03 35th Street, Long Island City, NY 11101
Telephone: 718-729-2020
Fax: 718-729-2941 / 800-899-8081

E-mail: info@mechoshade.com
Internet Web Site: <http://www.mechoshade.com>

4.49
MS2200 - 4/1/04



ElectroShade® Electrical Notes For Standard Motors

2. Wind-Activated Control (WAC): The WAC module is furnished with a "K" Value photo sensor. The WAC module has manual/auto mode selector plus master switching in the manual mode. An optional Remote Manual/Auto Switching Controller is available. Compatible with the MLC and IQ/MLC motor controllers. The IQ/MLC requires an optional interface.

3. 24-Hour Timer: A 24-hour timer is furnished with a remote manual override switch. Compatible with the MLC and IQ/MLC motor controllers. The IQ/MLC requires an optional interface.

4. IR or RF Remote Control (A/V or Bus): An IR or RF remote control through the use of a hand-held transmitter. Remote controls are available for the MLC and IQ/MLC Four Motor Controllers.

5. RS-232 Interface: RS-232 translates the RS-232 protocol for use with ElectroShade controllers. This addressable unit connects any PC, building automation or lighting system to the MLC and IQ/MLC Four Motor Controllers.

The RS-232/485 interface provides up to 5 zones per interface adapter, up to 12 IQ/MLC units per zone. Allows a total of 60 control units per interface.

RS232: P/N: EMLC 0232 RS MO (PC to 1st interface)
RS485: P/N: EMLC 0485 RS MO (interface 2 and up)

I•CON has a dedicated Wide Zone switch port for access to the entire system.

6. Switches: A complete line of low voltage and line voltage switches are available as:

- Paddle switches (maintained): for the MLC Four Motor Controllers.
- Rocker switches (maintained and momentary): for MLC Four Motor Controllers.
- Décor switches (pulse): for MLC and IQ/MLC Four Motor Controllers.
- Indoor key switches (maintained and momentary): for MLC and IQ/MLC Four Motor Controllers.
- Digital key pads: for MLC and IQ/MLC Four Motor Controllers.
- Plus, Lite-Touch Type H Series (or similar pulse type switch) for IQ/MLC Four Motor Controllers and I•CON Bus Line System:

IQ/MLC (full function up/down, stop with 3 intermediate stop positions on a 3-button single station or 6-button dual station switch).

I•CON (full function up/down, stop with 3 intermediate stop positions on a 4-button single station or 8-button dual station switch).

