

IQ/MLC2®

Networkable Motor Group Controller

Overview

The IQ/MLC2® is our next-generation, microprocessor-based motor controller. Building on the success of its predecessor, the IQ/MLC®, the IQ/MLC2 controls up to four standard line-voltage tubular motors and extends the DIP-switch-configurable group controls into a network solution capable of handling the most advanced daylighting and integration requirements.

A modular expansion port further enhances the flexibility of the product while also ensuring the product's ability to evolve with the changing needs and budget of the customer. Whether it's a single window or a whole-building motorized shade project, the IQ/MLC2 provides a scalable and flexible tool suitable for a wide variety of applications.

Features

Flexible group control

- Control of four standard line-voltage tubular motors (120 or 230VAC, 600W, ¼ hp max. per motor).
- Four local control ports for flexible dry-contact group control.
- Configuration of any combination of motors from any local port.
- Motor assignments that can be changed without tools or rewiring.

Extensible master control

- Two master control ports for dry-contact control of all internal motors simultaneously.
- Daisy-chaining to permit grouping of up to 2,000 motors.



Industry-leading uniformity

- Control ports with five alignment points: top and bottom limits, plus three programmable intermediate stops.
- Default presets at 25%, 50%, and 75% of shade travel.
- Customizable presets from the switch with no tools required.
- Uniform mode that restricts shades to programmed positions to manage a room's uniform-height aesthetic.

Control ports operating from virtually any manufacturer's dry-contact switch

- Supports rocker switches, keypads, hospital-bed pillow switches, and a variety of 3rd-party control equipment.
- Features momentary and maintained button-press operation.
- External control equipment powered by internal, isolated DC supply.

Versatile remote and wireless control options

- IR or RF control from a remote, smartphone, tablet, or 3rd-party system.

Eco-friendly technology

- Auto port providing automation and daylighting control through sensors and schedulers.
- Direct integration with SolarTrac® and SunDialer® WindowManagement® solutions.

Whole-building control network

- Internal two-way communication network provides control and feedback for up to 2,000 motors per segment.
- Eight network addresses for each motor, for multi-level group control.
- Network addresses for auto port and local control ports, for control across an entire network.
- Optional IP interface provides Ethernet integration and remote support and troubleshooting over the internet.

IQ/MLC2[®]

Networkable Motor Group Controller

Integration with 3rd-party equipment without extra interface components

- RS232 port for convenient serial interface with A/V, BAS, and lighting systems.
- Control ports providing dry-contact integration directly to any 3rd-party system.

Expansion-port modularly expands IQ/MLC2 functionality

- Four-motor expander card provides control of up to eight motors from a single IQ/MLC2 unit.
- Port provides capability for future enhancements.

Time-saving installation features

- Modular connectors and feedback LEDs for inputs and outputs allow simple wiring and troubleshooting.
- Reversible motor direction without rewiring.
- Setup, calibration, and changes to motors, presets, and operating modes that require no tools.

Reliable operation

- Second-generation technology.
- Flash-upgradable to support future enhancements.
- Spike and brownout protection.
- Listed: UL325 and CAN/CSA 22.2 No. 247-92.

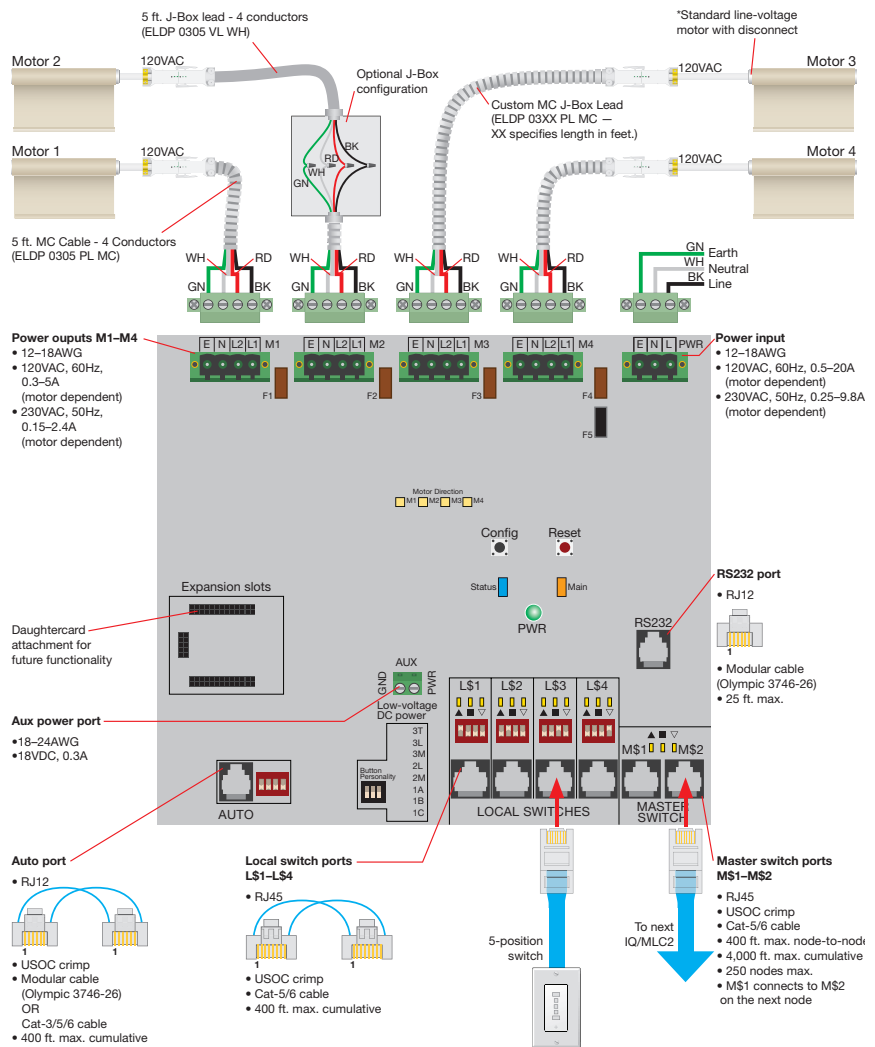

System Diagram

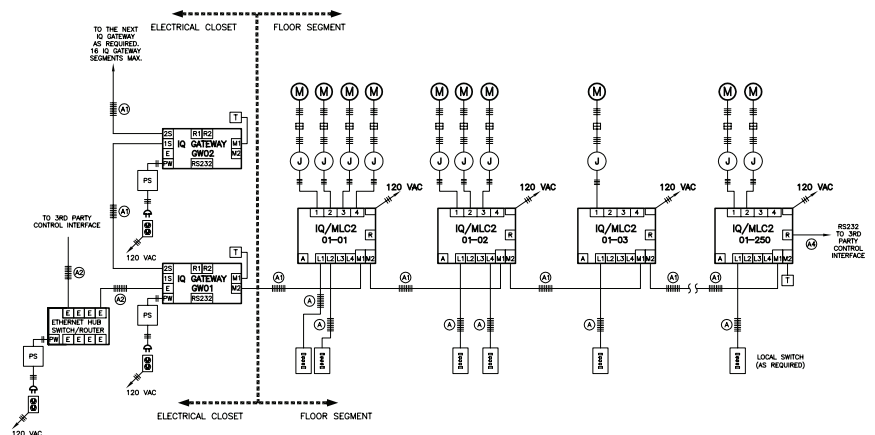

MechoSystems
Corporate Headquarters
42-03 35th Street
Long Island City, NY 11101

T: +1 (718) 729-2020
F: +1 (718) 729-2941
E: info@mechosystems.com
W: mechosystems.com